

COLOR	CODE #	PMS #	RAL #
GRAY ABS	508	429 C	7035
BLACK RUBBER	623	PROCESS BLACK	9005

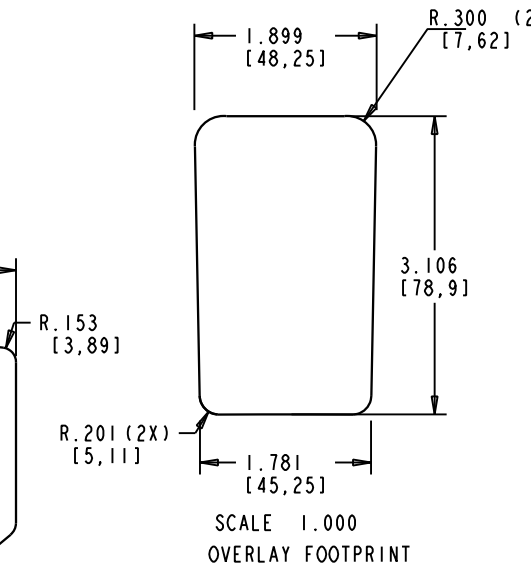

SECTION A-A

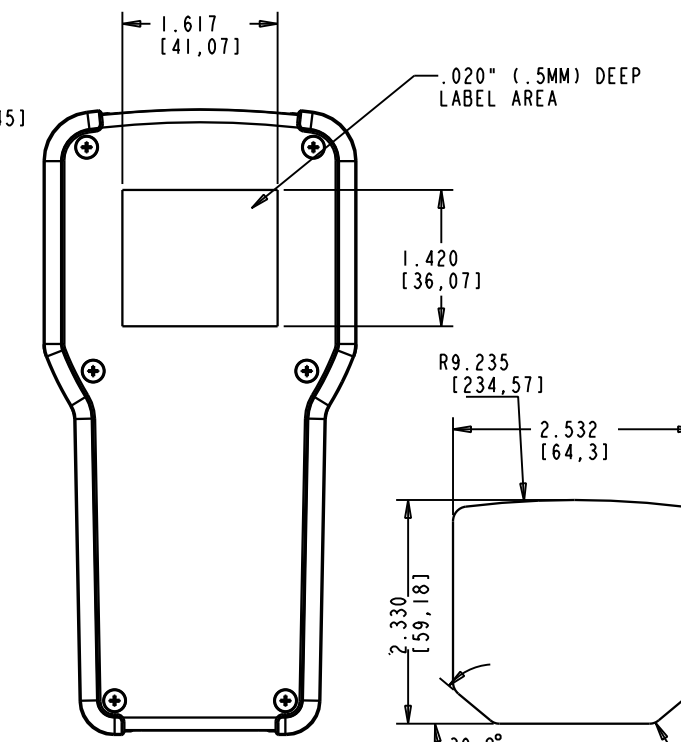
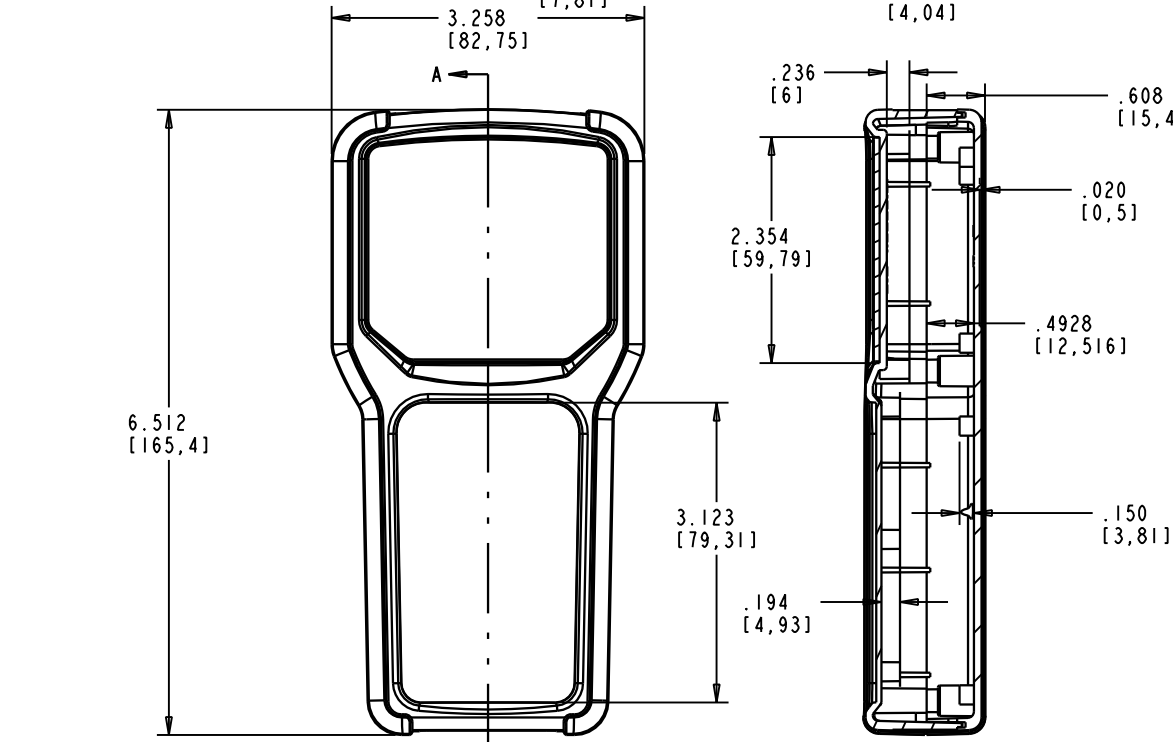

Gräfenau 58-60
D-75339 Höfen / Enz
Telefon (07081) 9540-0
Telefax (07081) 9540-90
Richard@WoehrGmbh.de
www.WoehrGmbh.de

Bezeichnung:
Industriegehäuse

Artikel-Nummer:
GH02KS046/700

Maße
in
mm