

SECTION A-A

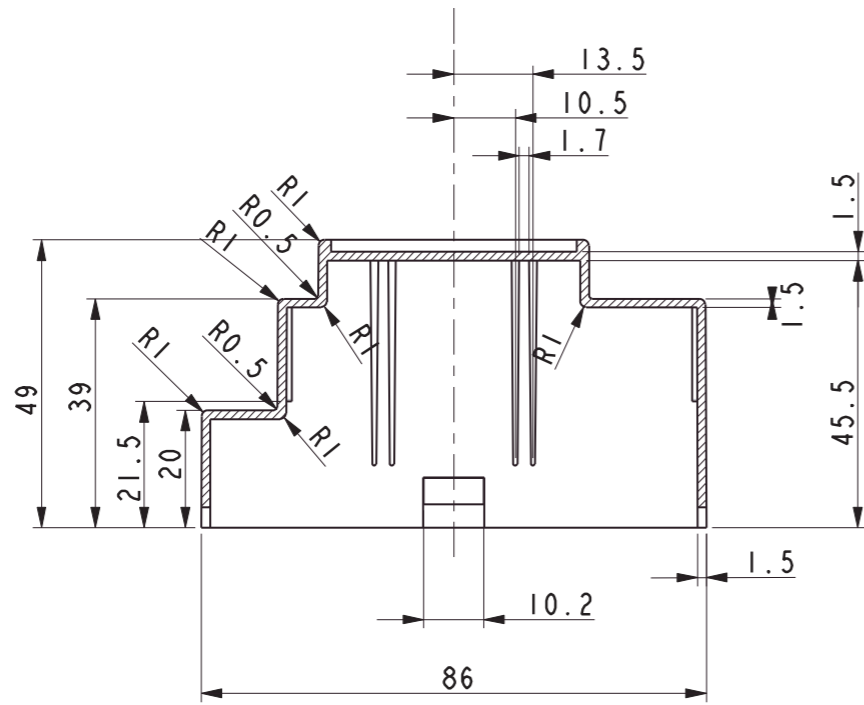

SECTION B-B

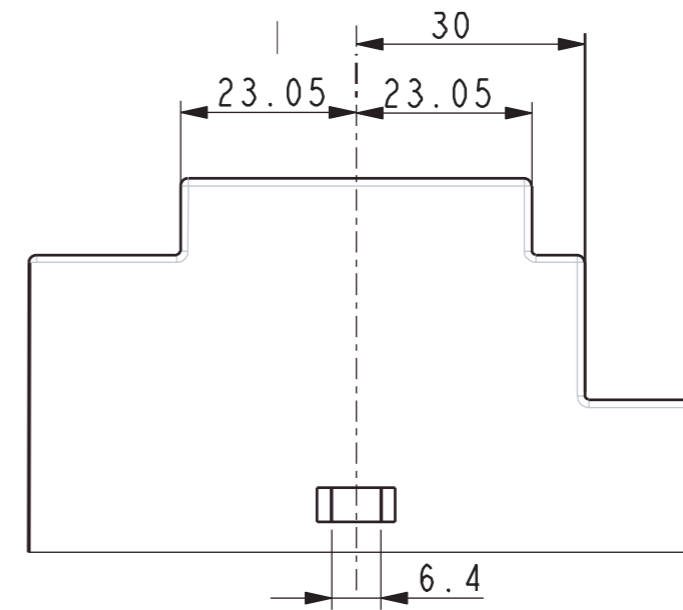
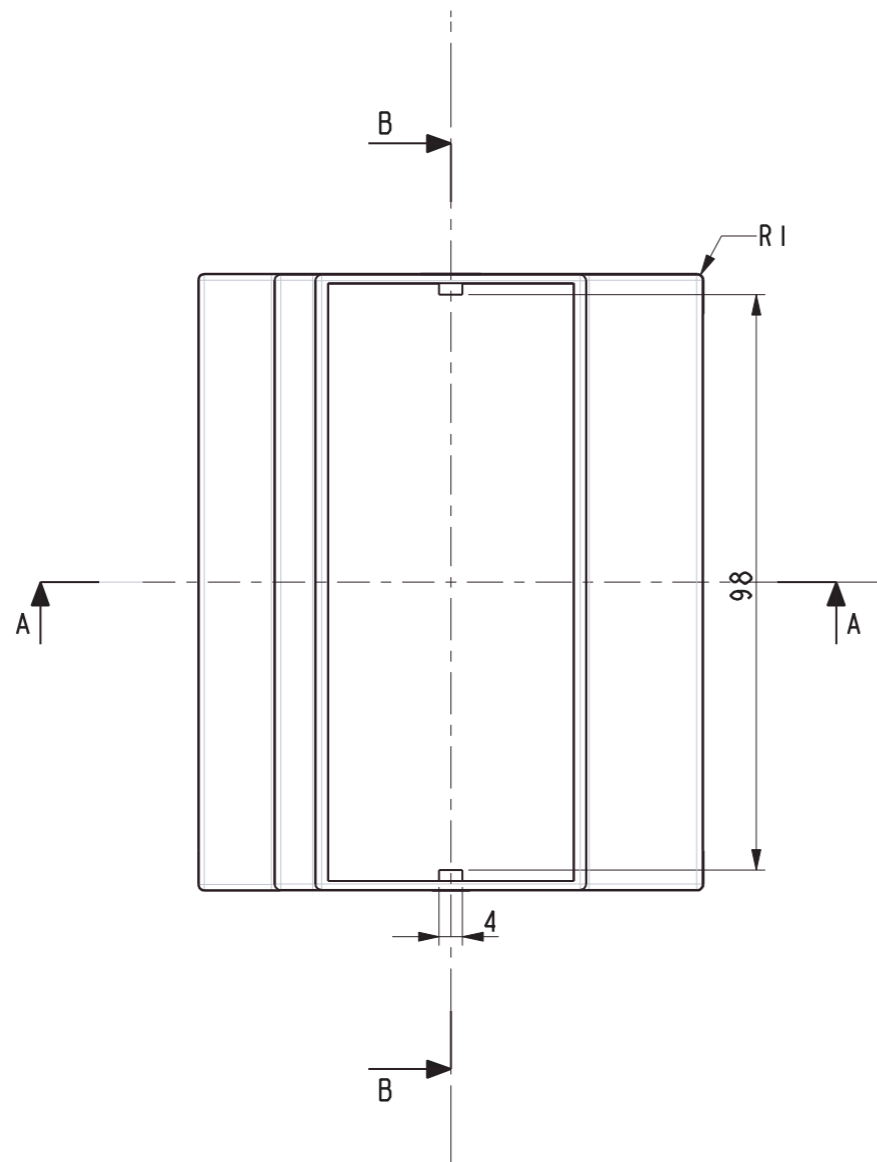
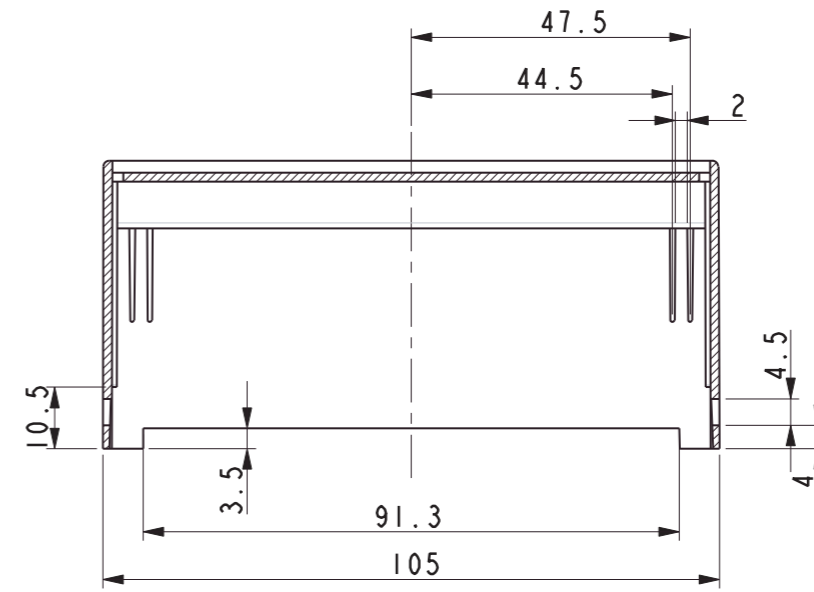

RICHARD WÖHR		Maßstab: 1:1		Gewicht:	
Schutzvermerk nach DIN 19016 beachten / Freimaßtoleranzen nach DIN 2768 mittel Not measured outlines take from the 3D- or dtd-data		Baugruppe: Serie HL		Kunde: 169999	
Bezh.	10.05.2017	J.Thumm			
Gepr.	16.05.2017	K.Maier			
Richard Wöhr GmbH D-75339 Höfen / Enz Richard@WoehrGmbH.de		Material: Lexan 940		Blatt 1	
Zust.	Änderung	Datum	Neue	Urspr.	Blz. 6